

**MPE19 electronic Potentiometer without Detent**  
**Part No. 4843522039-00**

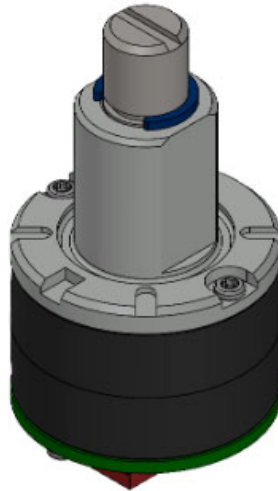

## DESCRIPTION

Electronic rotary potentiometer with wear-free HALL-sensing module for signal generation. Digit-exact fine adjustment through precise mechanical detent and stops with high rotational life. Perfect for use in industrial environments.

## TECHNICAL DATA

### CONSTRUCTION AND MECHANICAL DATA (TYPICAL VALUES, T=23 °C)

MECHANICAL ROTATION ANGLE	300°
DETENT ANGLE MECHANICAL	n.a.
DETENT GRADUATION	n.a.
MOUNTING	central mounting
PROTECTION CLASS	IP65 to the frontside between bushing and shaft
DETENT MECHANISM	n.a.
ADJUSTMENT TORQUE	1-2 Ncm
DETENT TORQUE WITH INDEX	n.a.
BEARING	friction
STOP STRENGTH MIN.	> 0,7 Nm
FASTENING TORQUE MAX.	2,0 Nm
LIFE EXPECTANCY (TYPICAL)	1.000.000 cycles
SHAFT LENGTH AND DESIGN	acc. drawing (customizable)
MOUNTING MATERIAL INCLUDED	wave spring washer nut M10x0,75

### ELECTRICAL DATA (TYPICAL VALUES, T=23 °C)

OPERATION VOLTAGE	5 VDC ± 10 %
CURRENT CONSUMPTION	5 mA typ., max. 7,5 mA
OUTPUT SIGNAL	0V - VCC ± 10 %
<b>MIN. RESISTIVE OUTPUT LOAD (CONT.)</b>	100 kΩ
MAX. CAPACITIVE OUTPUT LOAD	1 nF
INDICATOR OF REVOLUTION DIRECTION	voltage rising linear clockwise
ELECTRICAL DETENT	acc. output signal drawing
TOLERANCE OUTPUT VOLTAGE TO MECHANICAL GRADUATION	+/-2%
INSULATION RESISTANCE	>10 MΩ at 500 V DC
DIELECTRIC STRENGTH	500 V DC
CONNECTOR	MicroMatch (TE 7-188275-4) or similar

## ENVIRONMENTAL CONDITIONS

OPERATING TEMPERATURE	-10°C to +60°C (others on request possible)
STORAGE TEMPERATURE	-30°C to +85°C
HUMIDITY	20% to 75% r.H. not condensing
REACH AND ROHS	conform

## PINOUT AND DRAWINGS

### PINOUT AND DESCRIPTION

PIN	SIGNAL	DESCRIPTION
1	GND	Power supply ground
2	Signal Output	Potentiometer analog output signal
3	VCC	Positive power supply
4	n.c.	Do not connect

Voltage levels for power supply and encoder output voltage are defined in table electrical data.

## OUTLINE DRAWING

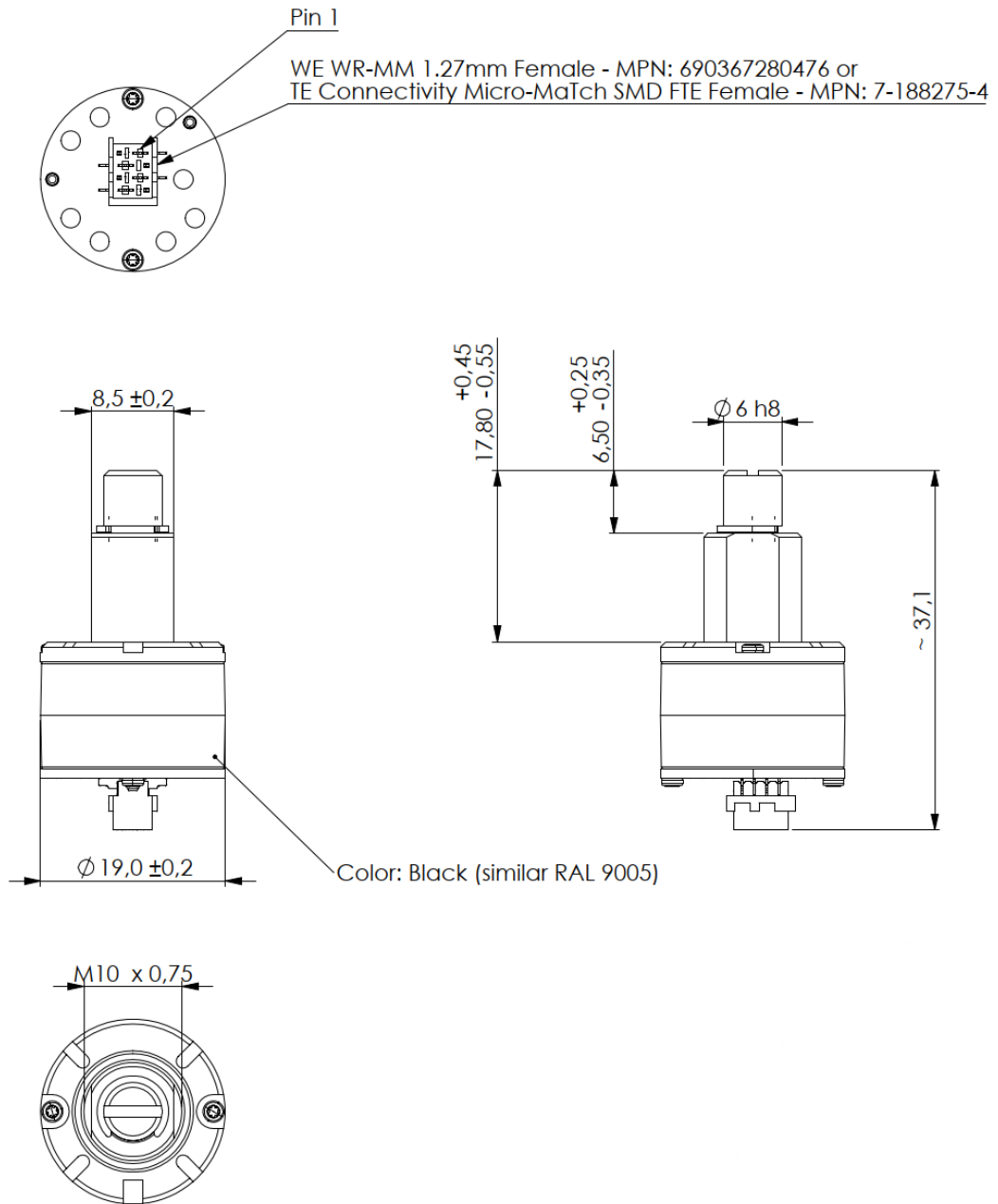

Units in mm

## OUTPUT SIGNAL REVOLUTION CW

The analog output value depends on the angle of the potentiometer axis, having a linear function between 16 and 284 degrees.

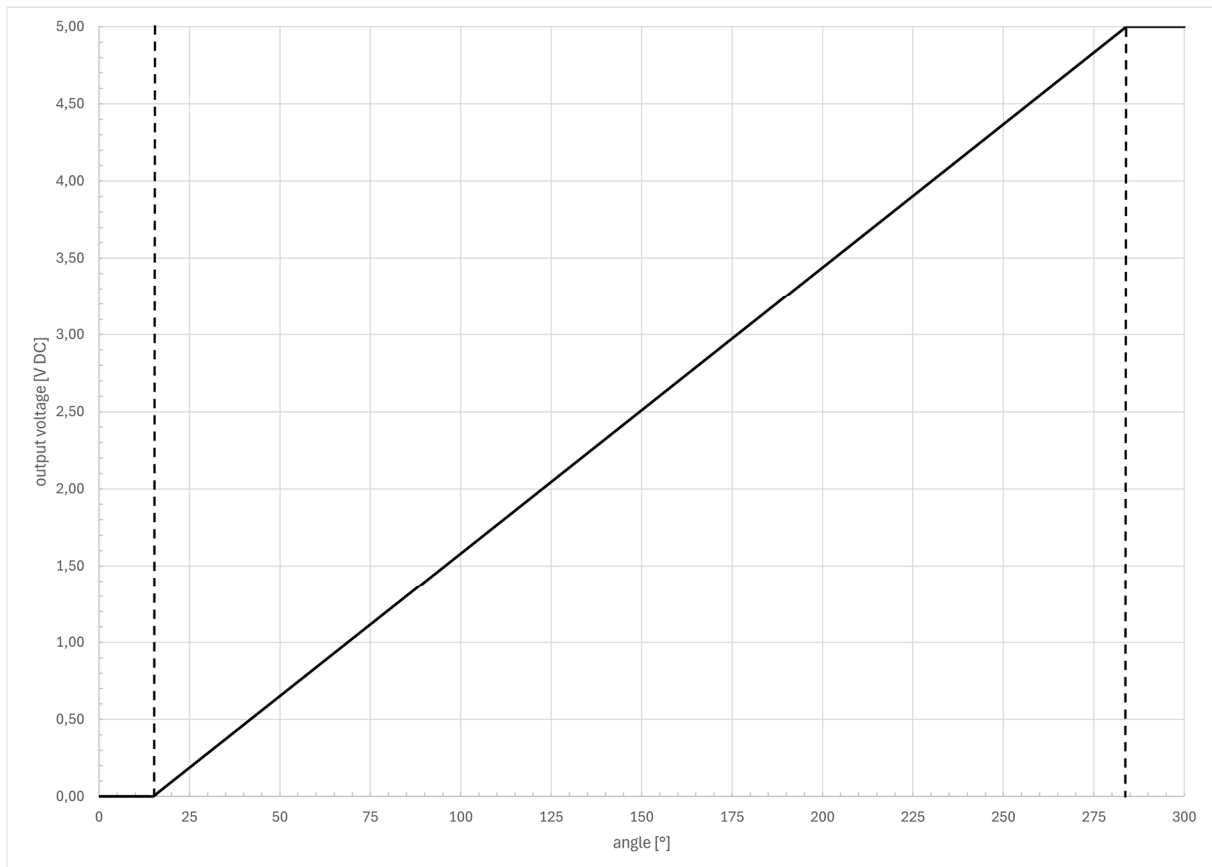

Output voltage level can be calculated by using this equation between 16 and 284 degrees:

$$\text{output voltage [V]} = 0,0171 * \text{angle}$$

Output voltages lower than 16 degrees or higher than 284 degrees are mapped to Ground or VCC.

## DISCLAIMER

The information contained in this document is for general guidance only. The user is responsible for determining the suitability of the technical information referred to herein for his application. On delivery of the component, EBE is only obliged to implement those properties set out and agreed upon in this technical data sheet. Further properties are not included. No guarantee is given. The component has been designed for installation in our customer's products. Manufacturer of the resulting product and consequent liability according to the Product Liability Act lies with the customer.

## REVISION

REVISION	DATE	DESCRIPTION
1.0	08.04.2025	Initial release